

Delivery of Water and Sanitation to the Urban Poor

A Public – Private Partnership Model that Works

John Martin and
Andy Narracott



CIWEM Annual Conference



7th April



Delivery of Water and Sanitation to the Urban Poor

- Introduction to WSUP
- The problem - “urbanisation”, the rapid growth of cities
- Part of the solution - the “public - private partnerships”
- Examples of WSUP’s innovative ideas
- Way forward



- Set up in 2005
- “Not for profit” organisation
- Collaboration from private sector, civil society and academia
- Focus on water, sanitation and hygiene
- Initial DFID support - now supported by likes of Gates Foundation, US Aid and AusAid



focus in 8 countries

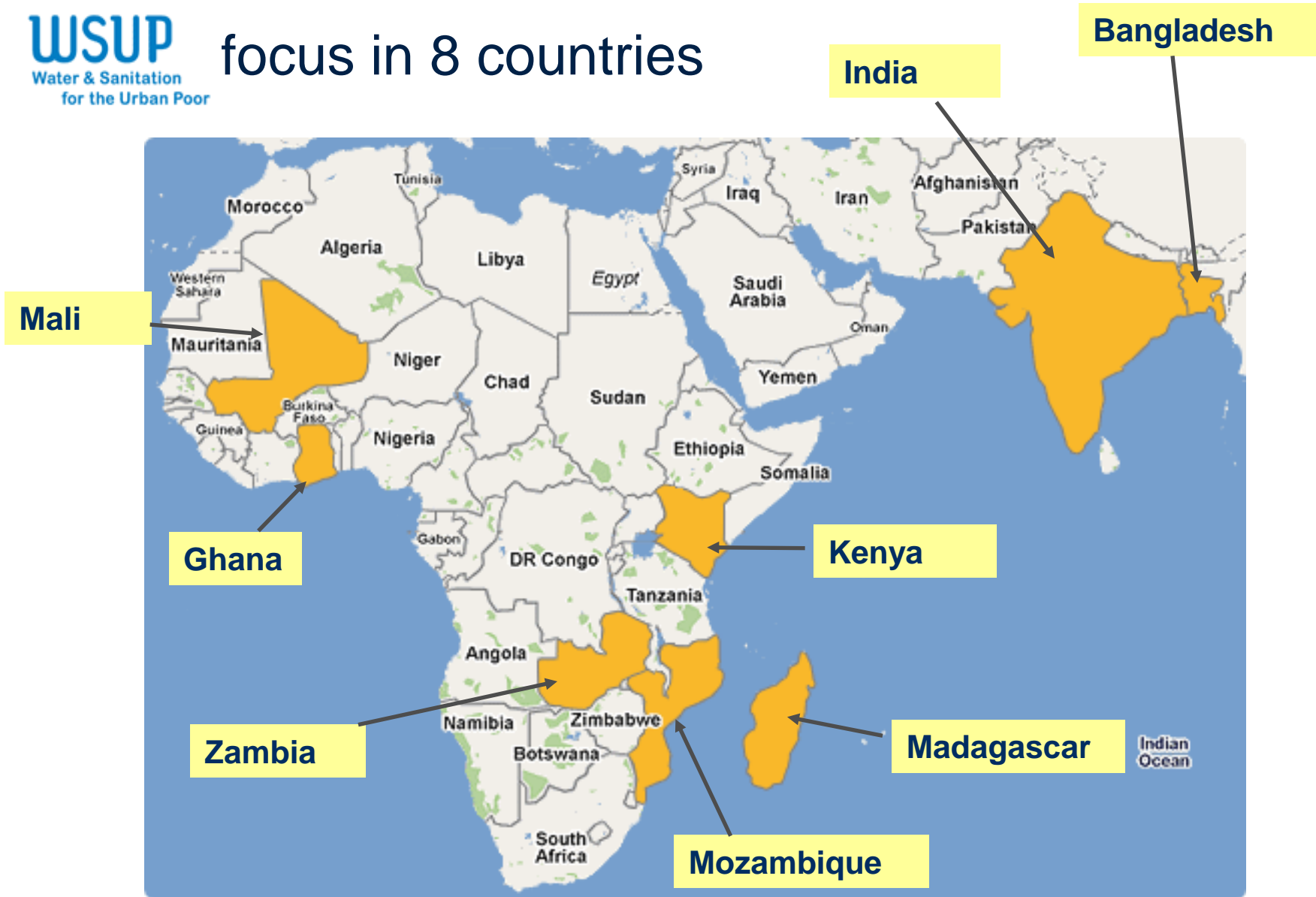

The problem – the rapid growth of cities

- Unplanned / informal settlements - *peri-urban areas*
- 828 million people in the settlements, lacking adequate water facilities
- 180,000 added each day - *moving target*
- 83% in Africa in urban areas by 2050
- Challenge for health and protection of water resources





Peri-urban area

Problems in the Peri-urban areas



objectives

- Millennium goals (7C)
 - Halve number without water and sanitation in 1990 by 2015
- Create legitimate fee paying customers
 - 3.5 million by 2015
- Targeted outcomes
 - Better services
 - Stronger service provider
 - Learning
 - Advocacy
 - Sustainable partnerships

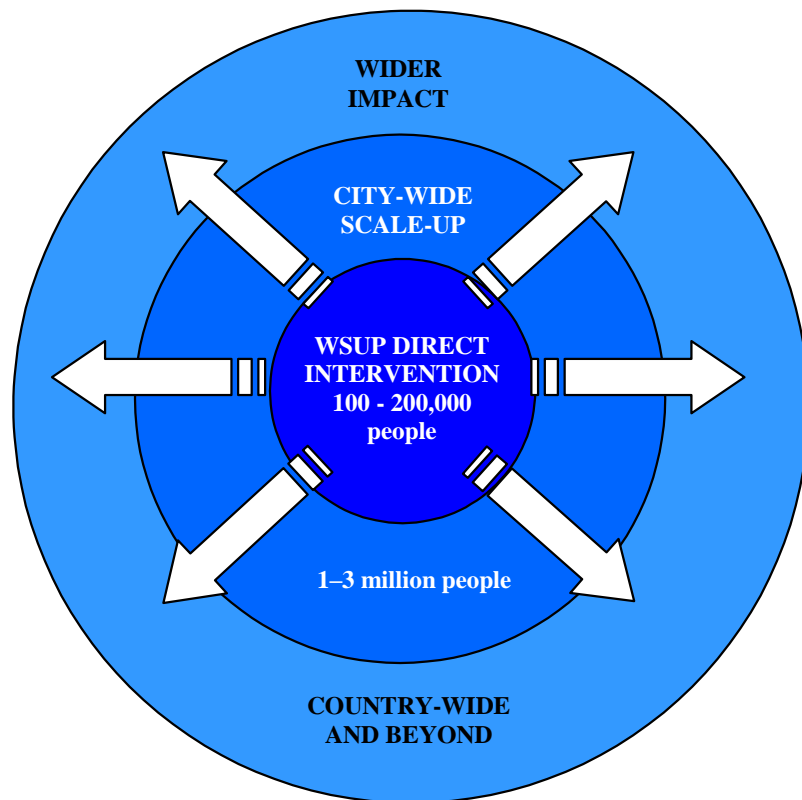

Working with the Local Service Providers (LSP)



Dhaka Water Supply and Sewerage Authority

- Target improved “levels of service”
- Capacity building
- Introduce sound business principals
- Financially sustainable - improved financial management and accounting practices

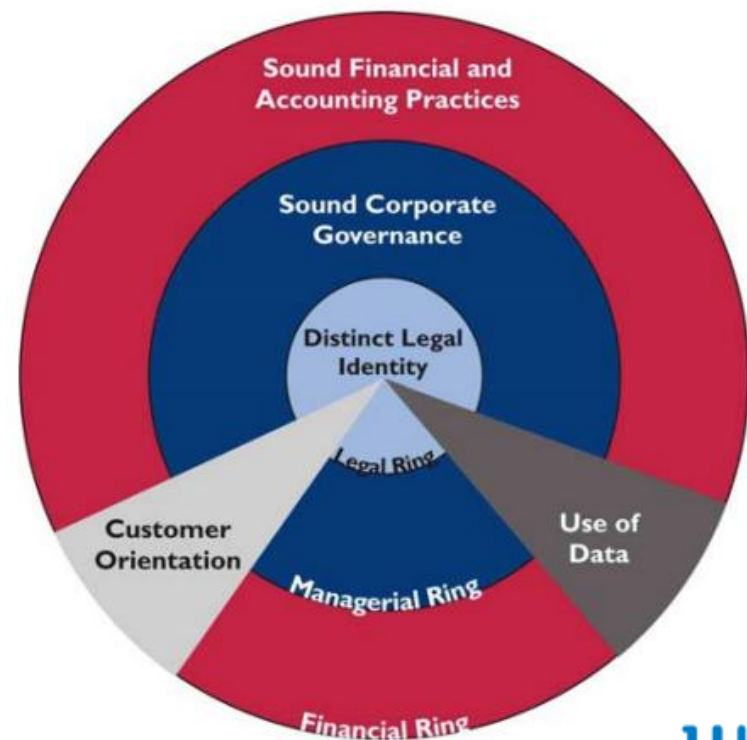

Private sector participation

- Important aspect of the WSUP model
- Extension of services to “last mile” - hardest part
- Establish partnerships with private sector
 - Business attractive
 - Both large and small scale
- Appropriate financial return



Working with communities

- Create legitimate paying customers
- Urban poor or low income customers?
- 1 billion people - significant purchasing power
- Give consumer voice a voice

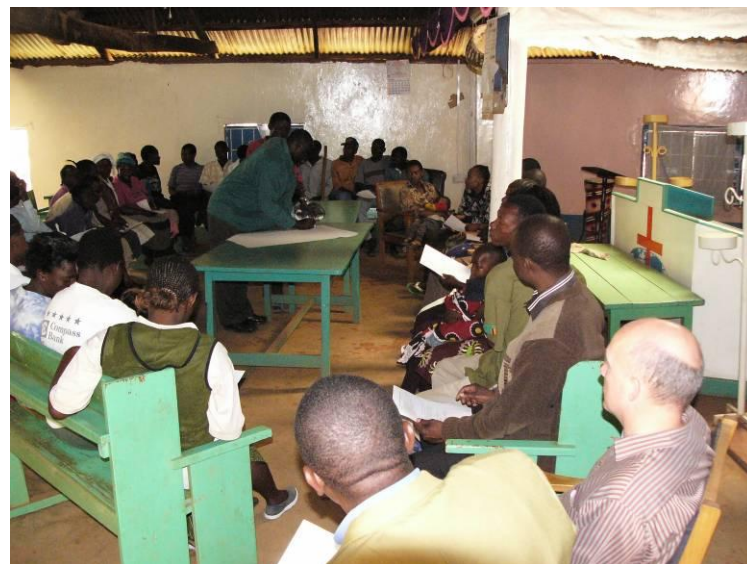

Several innovative ideas for service delivery



- Ideas now tried and tested
- Share knowledge
- Replication by others



Delegated management of water services – Naivasha Kenya

- Private and public sector partnerships
 - Clear contracts
 - Provide financial incentives for private sector involvement
 - Reliable billing and revenue collection
- Targets
 - Improved level of service for consumers
 - Affordable but profit for operators
 - Revenues for sustainable asset maintenance

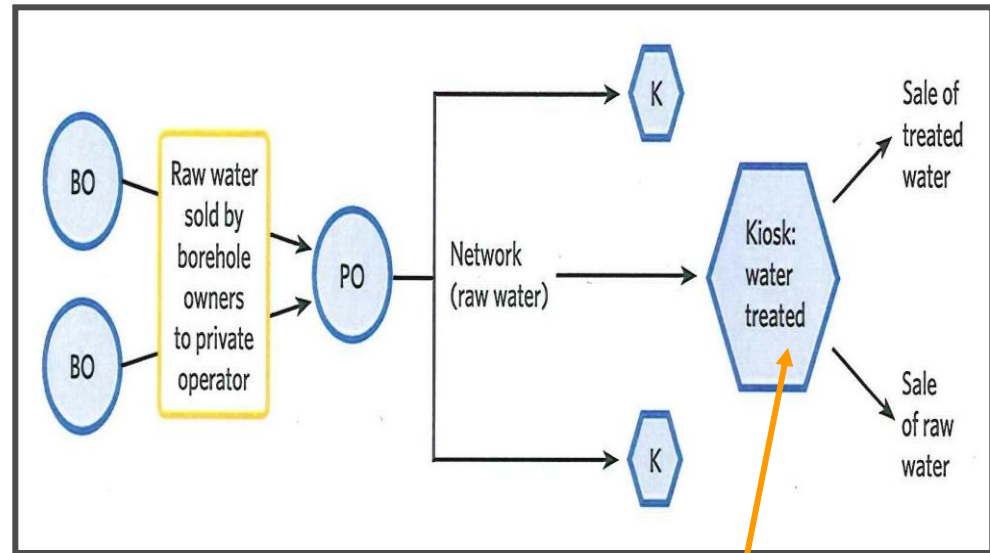

Water kiosk revenues to cross finance environmental hygiene - Tana, Madagascar

- Public health improvements - flood prone area
- Water kiosks fund canal cleaning and other uses
- Operating in 8 districts so far
- Concerns:
 - Maintaining community commitment
 - Workers protected
 - Disposal is appropriate



Communal sanitation – Maputo, Mozambique

- High density, low income communities
- Challenges
 - Effective community management
 - Achieve regular payments from users
 - Setting realistic tariff of ~ US\$3 per family/month
 - Achieving financial sustainability
- Replication
 - Serve 15 to 60 households
 - Need for more similar facilities



Summary and the way forward

- Targeting Millennium goals
- Strategic partnerships - public and private sectors
- Innovative models for service delivery
- Share knowledge and ideas
- Replicate and scale up
- IFIs to include peri-urban areas in wider city based projects



Thank you

More information at

WSUP.com

and

here at the Halcrow stand

